

未注公差/General tolerances(mm)											0.1/10 ±2'		
0	>3	>6	>10	>18	>30	>50	>80	>120	>180	>250		>315	>400
~3	~6	~10	~18	~30	~50	~80	~120	~180	~250	~315	~400	~500	~500
±0.12	±0.18	±0.22	±0.26	±0.31	±0.37	±0.57	±0.80	±0.93	±1.05	±1.15	±1.60	±2.20	±2.50

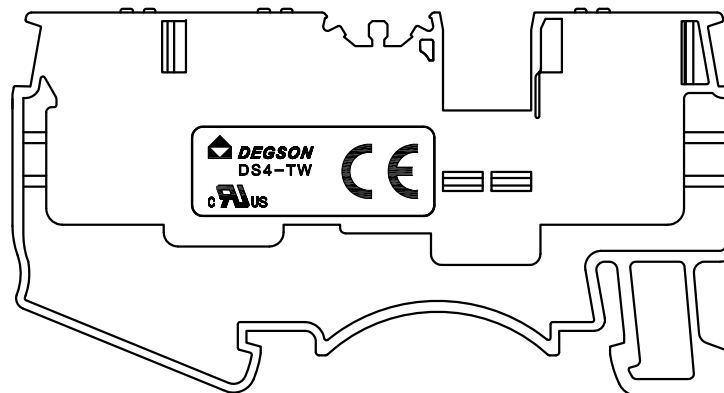
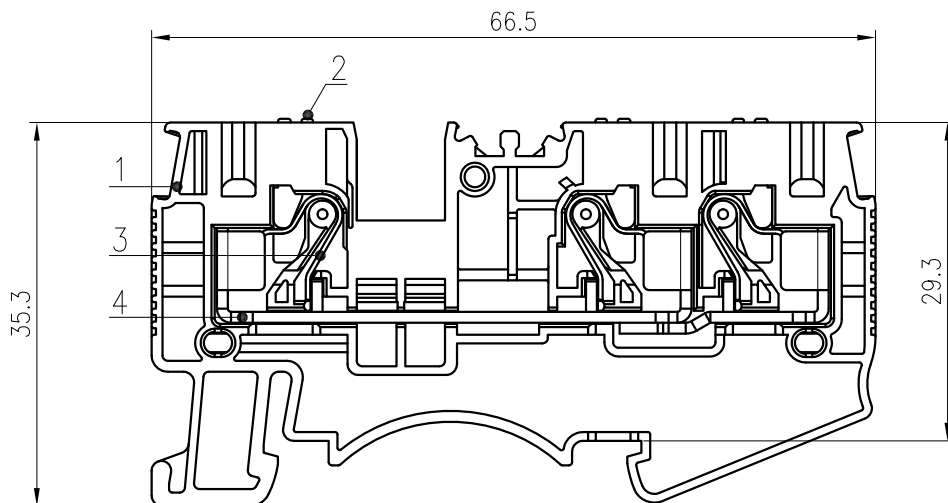

UL 标准/UL Standard:	B	C	D
额定电压/电流/Rated Voltage(V)/Current(A)	600/30	600/30	600/5
EC 标准/IEC Standard:			
过压类别/Overvoltage Category/污染等级/Pollution Degree	III/3	/	/
额定电压/电流/Rated Voltage(V)/Current(A)	800/32	/	/
额定脉冲电压(KV)/Rate Impulse Voltage(KV)	8	/	/
线径范围(硬线和软线)/Wire Range(rigid and flexible)(mm <sup>2</sup> /AWG)	0.2~4,6(SOL)/24~10		
间距/Pitch(mm)	6.2		
剥线长度/Stripping length(mm)	10-12		
使用温度范围/Operating temperature(°C)	-40~+105		
符合RoHS环保要求/Conform to RoHS	Yes		

4	Current Carrier	Copper	Sn plated
3	Spring	Stainless steel	
2	Button	PA66-GF	UL94 V-0
1	Housing	PA66	UL94 V-0
ITEM	NAME OF PART	MATERIAL	NOTES

REV	ECN	DESCRIPTION	DRFT	DATE
-----	-----	-------------	------	------

MATERIAL: /	SURFACE: /		
MAT NO.: /	宁波高松电子有限公司 NINGBO DEGSON ELECTRICAL CO., LTD		
STATUS: /			
APPD: Li GL 2020.04.20	NAME: DS4-TW-01P-1Y-00A(H)		
CHKD: Mao J 2020.04.20	DRAWING NO.: DS4-TW-C01		
DRFT: Liu ZhH 2017.09.09	REV	D0-3	
SIZE: A4                                  TYPE: CUSTOMER DRAWING	SCALE: 1.5:1	SHEET	1/1