

REVISION RECORD				
REV	ECN	DESCRIPTION	DRFT	DATE

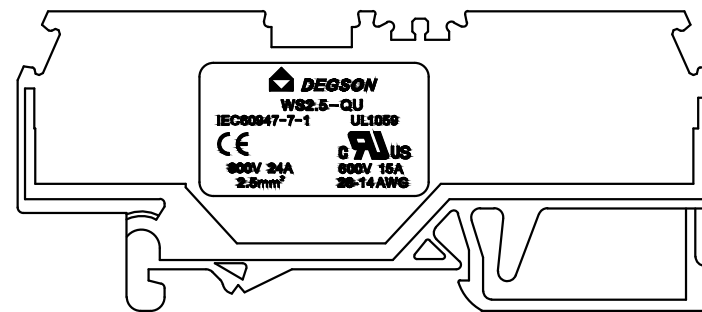
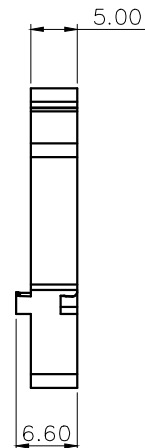
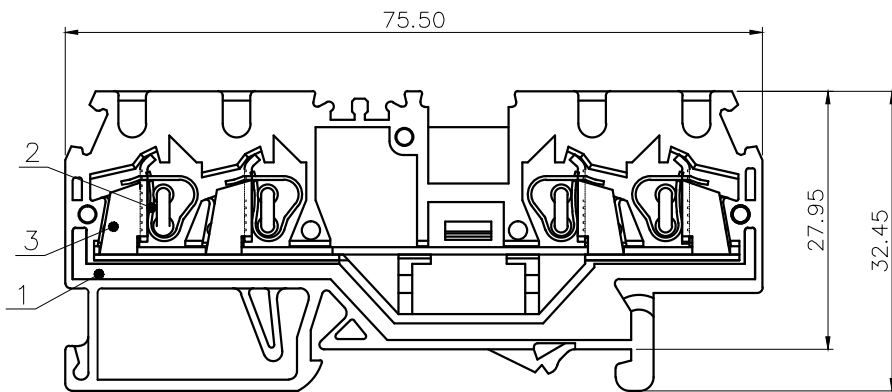

NOTES1:

UL Standard

- 1.Rated Voltage/Current : 600V / 15A
- 2.Withstanding Voltage : AC2200V/1Min.
- 3.Wire Range : 28~14AWG

IEC Standard

1. Pollution Degree	3
Overvoltage Category	III
Rate Impulse Voltage(KV)	8.0KV
Rate Voltage(V)	800V
Rate Current(A)	24A

2.Wire Range : 2.5mm²

NOTES2:

- 1.Dimension shall be interpreted per ASME Y14.5-2009
- 2.Pitch : 5.00mm, Poles : 01P
- 3.Stripping length : 9.0mm
- 4.Operating temperature: -40°C~+105°C
- 5.Undimensioned Tolerances:

Pitch range in mm		Nominal dimension range in mm					
TO	Over	TO	Over	TO	Over	TO	Over
6	10	10	30	30	60	60	150
6	10	24	30	60	100	150	150
±0.15	±0.20	±0.30	±0.30	±0.50	±0.70	±1.00	±1.30
							±2'

6.RoHS Compliance

3	Current carrier	Copper alloy	Sn plated
2	Spring	Steel	
1	Housing	PA66	UL94V-0
ITEM	NAME OF PART	MATERIAL	NOTES

DETACHED LISTS	PART NO.:	/		
	APPD:	Li GL 2020.06.05	NAME: DEGSON NINGBO DEGSON ELECTRICAL CO., LTD	
	CHKD:	Mao J 2020.06.05	WS2.5-QU-01P-1Y-100A(H)	
	DRFT:	XMY 2020.05.20	TITLE: CUSTOMER DRAWING	REV TO
THIRD ANGLE PROJECTION		DRAWING NO.:	WS2.5-QU-C03	SHEET 1/1
		MM (INCH)	DO NOT SCALE DRAWING	SCALE 1:1