

未注公差/General tolerances(mm)

0	>3	>6	>10	>18	>30	>50	>80	>120	>180	>250	>315	>400	>500	0.1/10 ±2'
~3	~6	~10	~18	~30	~50	~80	~120	~180	~250	~315	~400	~500		
±0.12	±0.18	±0.22	±0.26	±0.31	±0.37	±0.57	±0.80	±0.93	±1.05	±1.15	±1.60	±2.20	±2.50	

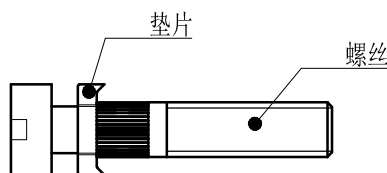
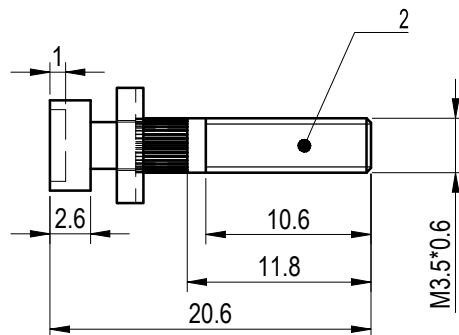
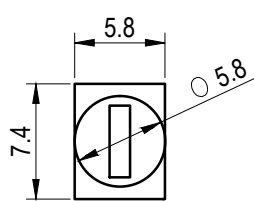
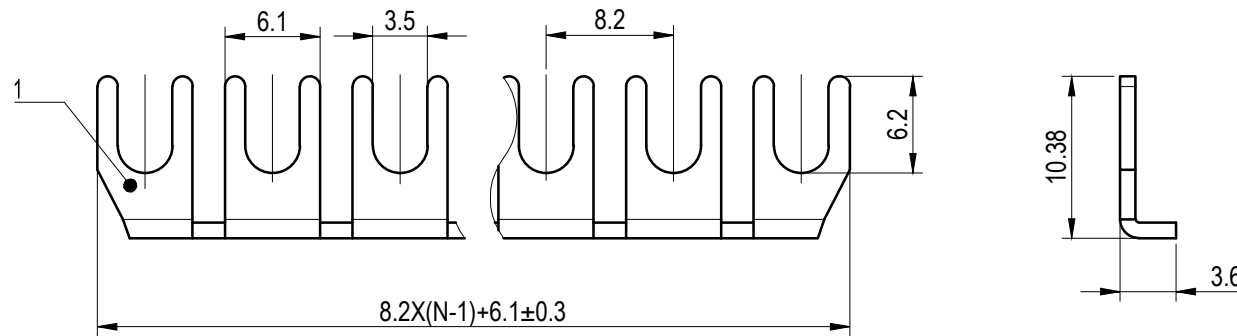

2	Screw	Copper alloy	Ni plated
1	Fixed Bridge	Copper	Sn plated
ITEM	NAME OF PART	MATERIAL	NOTES

螺丝扭矩/Torque Tightening(N·m/Lb.in)	M3.5 0.8/7.02
间距/Pitch(mm)/线数范围/Poles	8.2/N=02~10P
符合RoHS环保要求/Conform to RoHS	Yes

DEGSON	MATERIAL: /	SURFACE/COLOR: /
	MAT NO./REV: /	MAT STATUS: /

APPD: PengM	2022.06.20	NAME	FBXX-RTK/S		
CHKD: GaoWG	2022.06.20				

00	/	/	XieXD	2022.06.20	DRFT: XieXD	2022.06.20	DRAWING NO.	TYPE	DRAWING STATUS	SCALE	SHEET
REV	ECN	DESCRIPTION	DRFT	DATE			/	CUSTOMER DRAWING	/	2:1	1/1

Transfer or duplication of this document as well as the utilization or communication of its contents are prohibited unless explicit authorization is granted. Violations will be liable for compensation. All rights reserved for patent, utility model or designs registrations. 未经授权，禁止以任何形式复制或传播本文件内容，否则，侵权、泄密、交易本文件内容，使用者将承担法律责任。本公司保留对涉及发明、实用新型和外观设计的所有权利。