

公差/General tolerances (mm)												D		
0	>3	>6	>10	>18	>30	>50	>80	>120	>180	>250	>315		>400	>500
~	~	~	~	~	~	~	~	~	~	~	~	~	~	~
±0.12	±0.18	±0.22	±0.26	±0.31	±0.37	±0.57	±0.80	±0.93	±1.05	±1.15	±1.60	±2.20	±2.50	±2

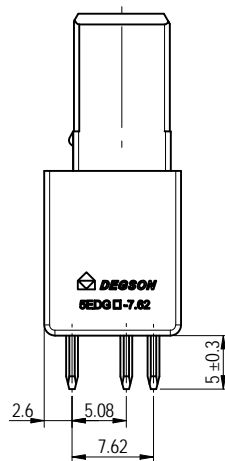
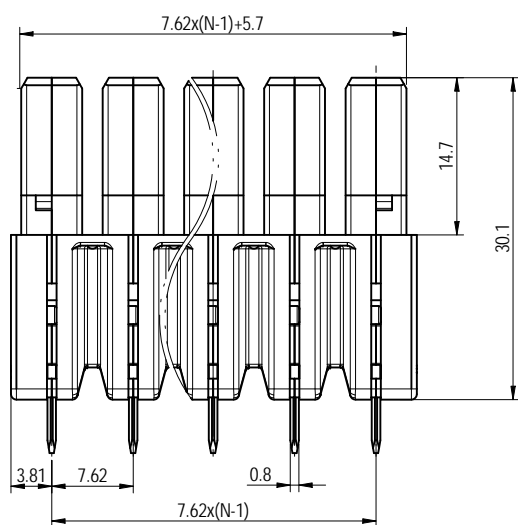
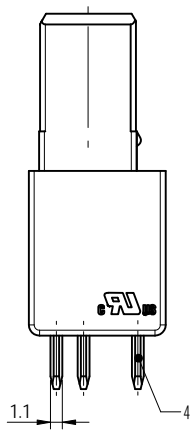
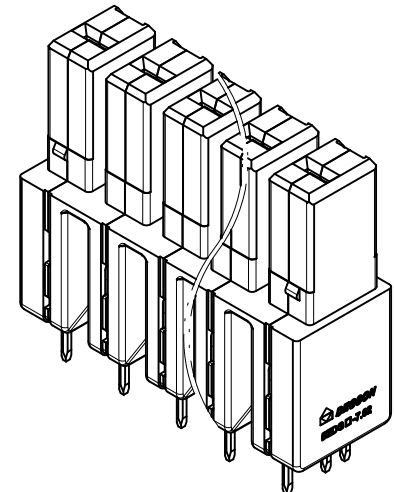
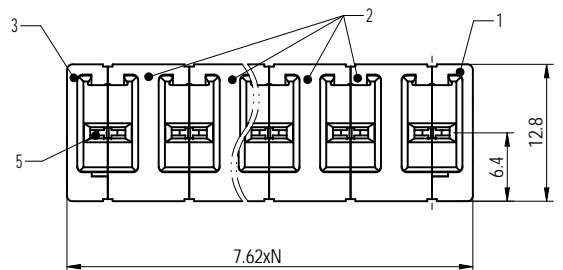

5	Spring	Stainless steel	/
4	Clamp	Copper alloy	Sn Plated
3	Side Housing2	PA66	UL94V-0
2	Mid Housing	PA66	UL94V-0
1	Side Housing1	PA66	UL94V-0
ITEM	NAME OF PART	MATERIAL	NOTES
UL 标准/UL Standard:		B	C
额定电压/电压/Rated Voltage(V)/Current(A)		300/41	300/41 600/5
IEC 标准/IEC Standard:			
过压类别/Overvoltage Category/污染等级/Pollution Degree		III/3	III/2 II/2
额定电压/电压/Rated Voltage(V)/Current(A)		630/41	800/41 1000/41
额定脉冲电压(KV)/Rate Impulse Voltage(KV)		6	6 6
间距/Pitch(mm)/线数范围/Poles		7.62/N=02~12P	
使用温度范围/Operating temperature(°C)		-40~+105	
符合RoHS环保要求/Conform to RoHS		Yes	

	MATERIAL:	SURFACE/COLOR:		
	MAT NO./REV: - / 00	MAT STATUS: 批量		
APPD: 兰春华	2023.09.01	NAME:	5EDGB-7.62-XXP-1Y-00Z(H)	
CHKD: 黄耀志	2023.09.01	DRAWING NO.	TYPE	DRAWING STATUS
DRFT: 周锦雄	2023.08.31	200021499	CUSTOMER DRAWING	SCALE
REV	ECN	DESCRIPTION	DRFT	DATE
00			周锦雄	2023.08.31
①	A3	1:1	1/1	

REV	ECN	DESCRIPTION	DRFT	DATE	DRAWING NO.	TYPE	DRAWING STATUS	SCALE	SHEET
00			周锦雄	2023.08.31	200021499	CUSTOMER DRAWING	已发布	1:1	1/1

Transfer or duplication of this document as well as the utilization of its contents without the written permission of DEGSON is prohibited. All rights reserved for patent. 复制或再行发布此文件以及其内容之利用，未经DEGSON书面许可，均属侵权行为。DEGSON保留所有权利。未经许可，不得复制或再行发布此文件及其内容。