

Transfer or duplication of this document as well as the utilization or communication of its contents are prohibited unless explicit authorization is granted. Violations will be liable for compensation. All rights reserved for patent, utility model or design registrations. 除专利、实用新型、外观设计、发明专利、注册商标、商標、利用、交流、本文件的内容，未经授权，不得复制或传播。本公司保留所有权利。

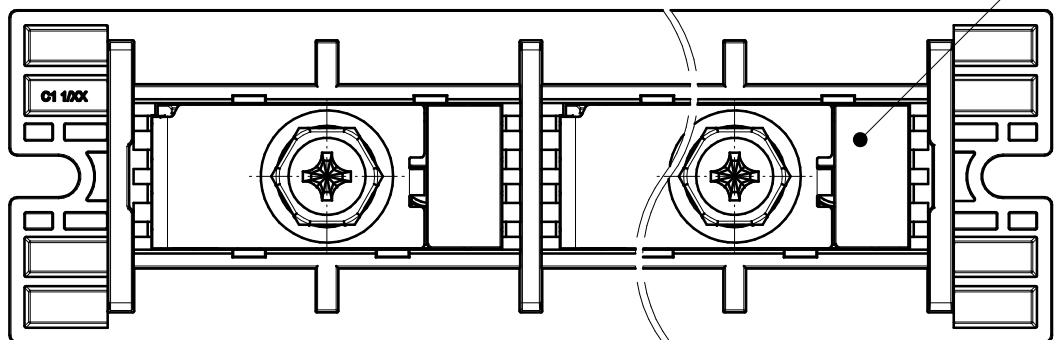

未注公差/General tolerances(mm)												
0	>3	>6	>10	>18	>30	>50	>80	>120	>180	>250	0.1/10	
~3	~6	~10	~18	~30	~50	~80	~120	~180	~250	~315	±2'	
±0.12	±0.18	±0.22	±0.26	±0.31	±0.37	±0.57	±0.80	±0.93	±1.05	±1.15		
UL 标准/UL Standard:										B	C	D
额定电压/电流/Rated Voltage(V)/Current(A)										600/200	600/200	600/5
工频耐压/R.M.S withstand voltage										AC2200V/1Min		
螺丝扭矩/Torque Tightening(N·m/Lb.in)										M8, 6.0/53.1		
线径范围(硬线和软线)/Wire Range(rigid and flexible)(AWG)										2~3/0		
线数范围/Poles										N=02P/4P		
使用温度范围/Operating temperature(°C)										-40~+105		
符合RoHS环保要求/Conform to RoHS										Yes		

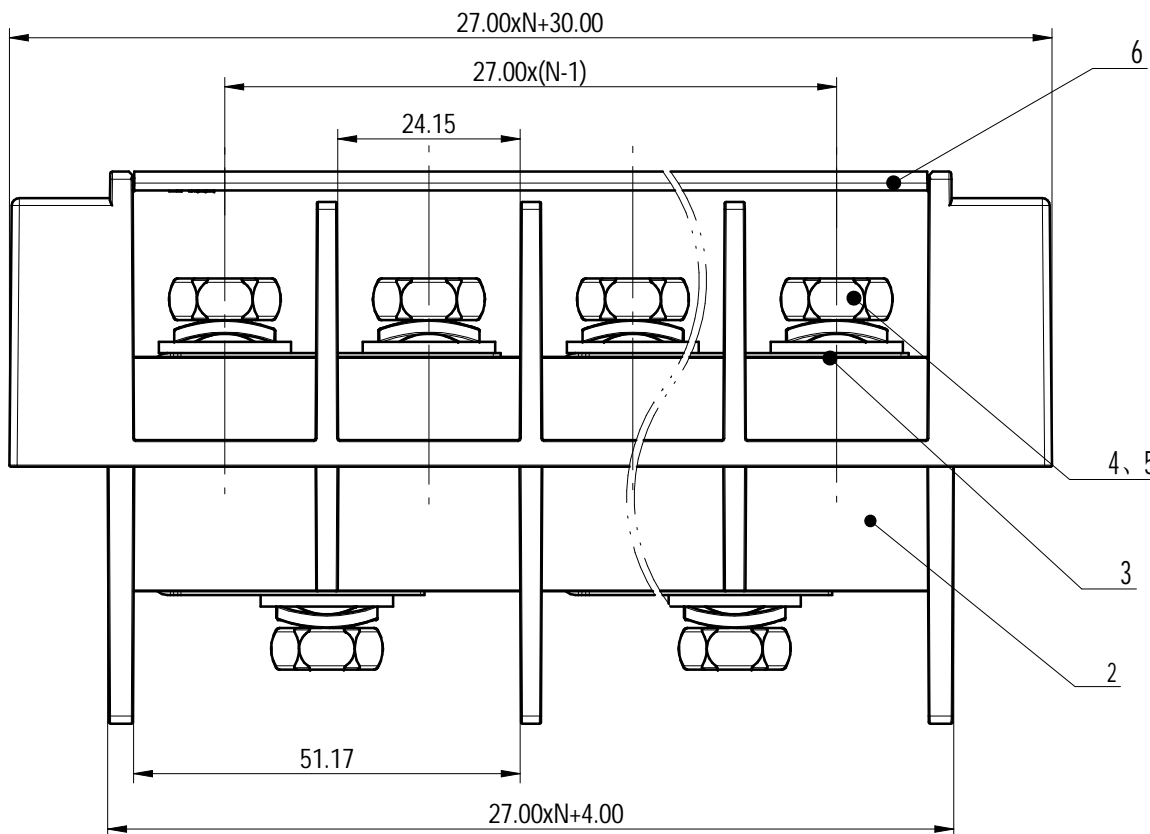
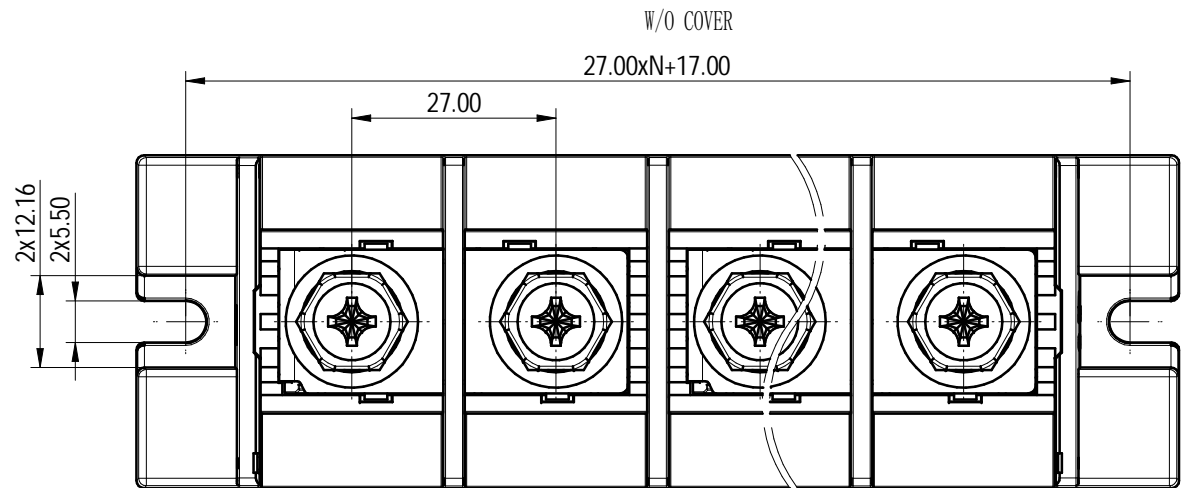
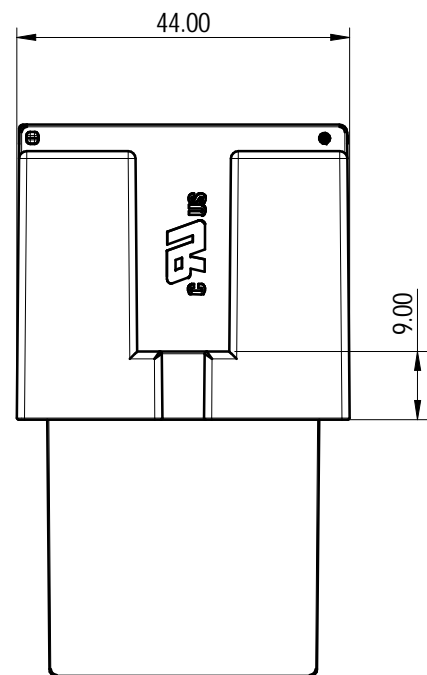
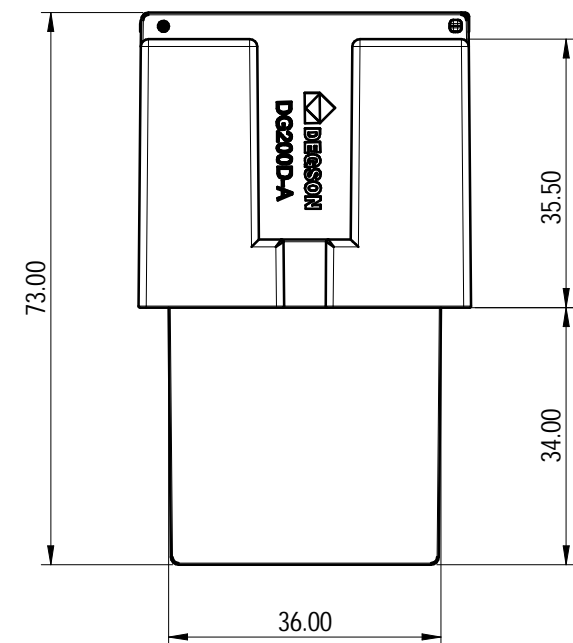

ITEM	NAME OF PART	MATERIAL	NOTES
6	Cover	PC	UL94V-2
5	Nut	Steel	Zn Plated
4	Screw	Steel	Zn Plated
3	Current_carrier	Copper	Ni Plated
2	Housing	PA66+GF	UL94V-0
1	Fixator	PA66+GF	UL94V-0

**DEGSON** MATERIAL: / SURFACE/COLOR: /  
 MAT NO./REV: / /00 MAT STATUS: /  
 APPD: 蓝贵凡 2023.08.25 NAME  
 CHKD: 曹利彬 2023.08.25  
 DRFT: 汪德荣 2023.08.25  
 DRAWING NO. 200217718 TYPE PRODUCT DRAWING DRAWING STATUS / SCALE 1:1 SHEET 1/1

REV	ECN	DESCRIPTION	DRFT	DATE
00	/	/	汪德荣	2023.08.25